

3113KIT - 3113KIT

PORTAVALIGIE LATERALE SPECIFICO - SPECIFIC TUBULAR SIDE-CASE HOLDER - PORTE-VALISES LATÉRAUX SPÉCIFIQUE
SPEZIFISCHES STAHLROHR-SEITENTRAEGER - PORTA MALETAS LATERALES ESPECÍFICO - TRONCO LADO ESPECÍFICO

SUZUKI GSX-S 750 F (2017)

N°	Descrizione	Caratteristiche	Codice	Quantità
1	Supporto inferiore - Lower support - Support inférieur - Soporte inferior - Untere Halterung - Soporte inferior	-	GNB1912V	1
2	Vite - Screw Vis - Schraube Tornillo - Parafuso	TCEI M6x35	635TCEI	4
3	Rondella - Washer - Rondelle Scheibe - Arandela - Arruela	Rondella Spaccata	Z1063	4
4	Rondella - Washer - Rondelle Scheibe - Arandela - Arruela	-	618RON	4
5	Dado - Bolt - Ecrou Mutter - Tuerca - Porca	Dado Cieco	6DADICZN	4
6	Distanziale - Spacer Entretoise - Distanzstueck - Distanciador	-	V937	4
7	Distanziale - Spacer Entretoise - Distanzstueck - Distanciador	Ø18L17 Foro8,5	C18L17F8,5	2

3113KIT - 3113KIT

PORTAVALIGIE LATERALE SPECIFICO - SPECIFIC TUBULAR SIDE-CASE HOLDER - PORTE-VALISES LATÉRAUX SPÉCIFIQUE
SPEZIFISCHES STAHLROHR-SEITENTRAEGER - PORTA MALETAS LATERALES ESPECÍFICO - TRONCO LADO ESPECÍFICO

SUZUKI GSX-S 750 F (2017)

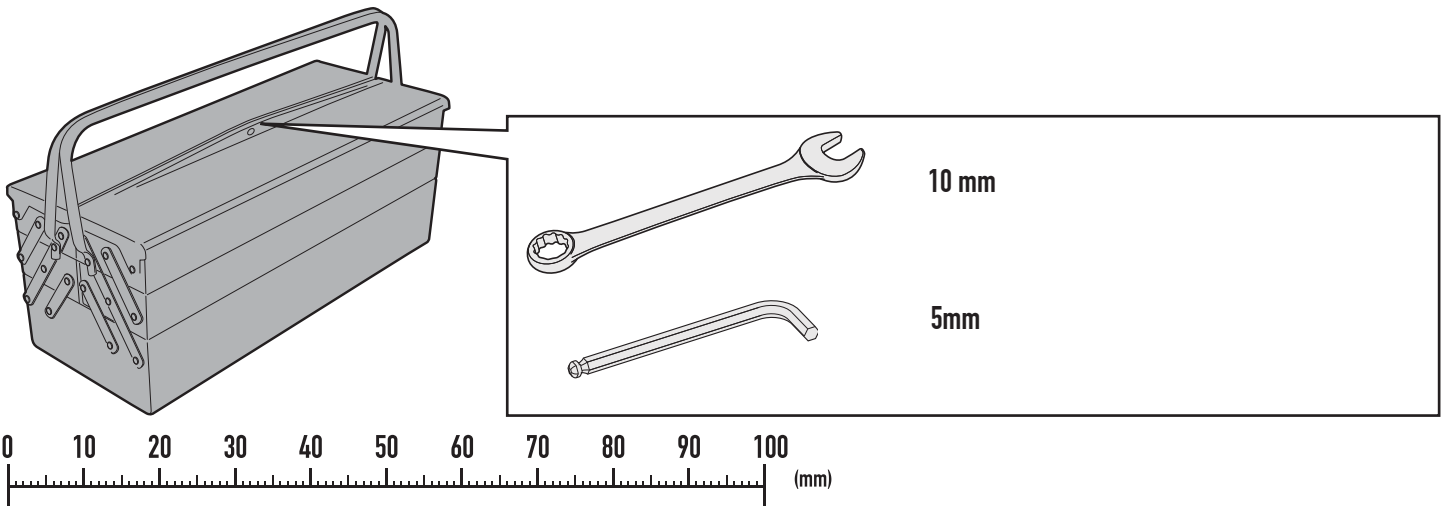
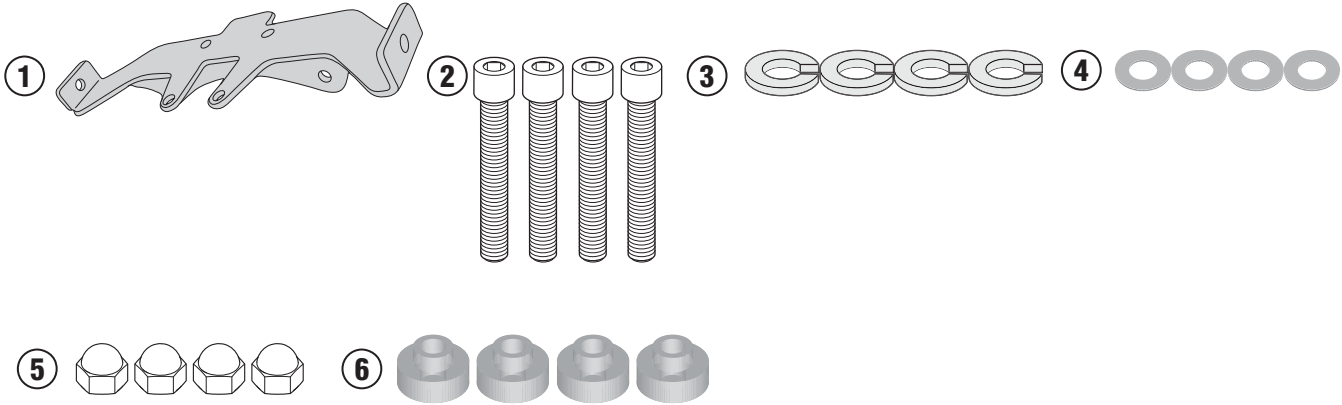

3113KIT - 3113KIT

PORTAVALIGIE LATERALE SPECIFICO - SPECIFIC TUBULAR SIDE-CASE HOLDER - PORTE-VALISES LATÉRAUX SPÉCIFIQUE
SPEZIFISCHES STAHLROHR-SEITENTRAEGER - PORTA MALETAS LATERALES ESPECÍFICO - TRONCO LADO ESPECÍFICO

SUZUKI GSX-S 750 F (2017)

